

~7 mm - fit to instrument

1/8 Ø

trompette rest

Dewit Hurdy-gurdy

Supplemental Plans - Keybox end block, string rests

FS (1" = 1")

Copyright 1996, Olympic Musical Instruments
v2.0 Feb 22, 1996

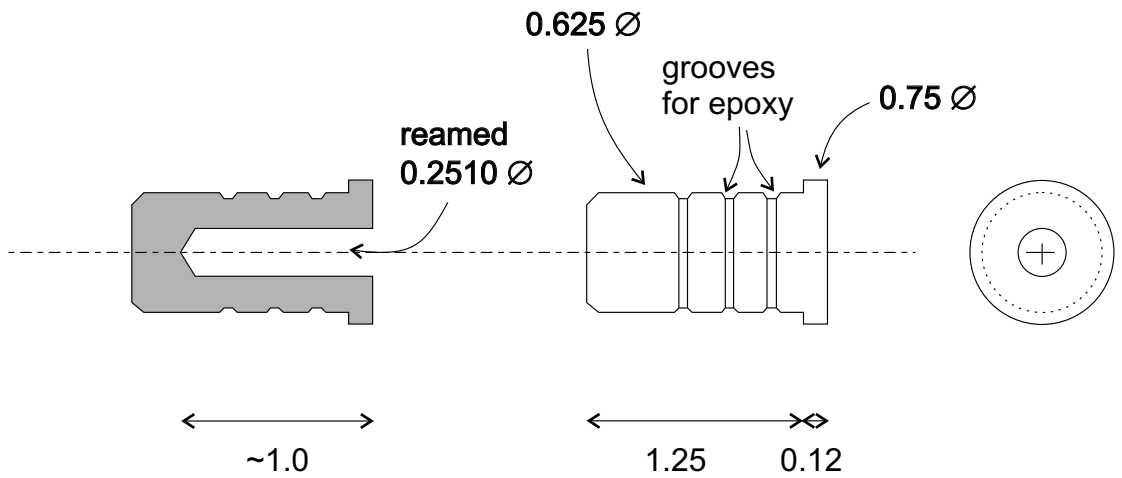

head bearing

material: Delrin

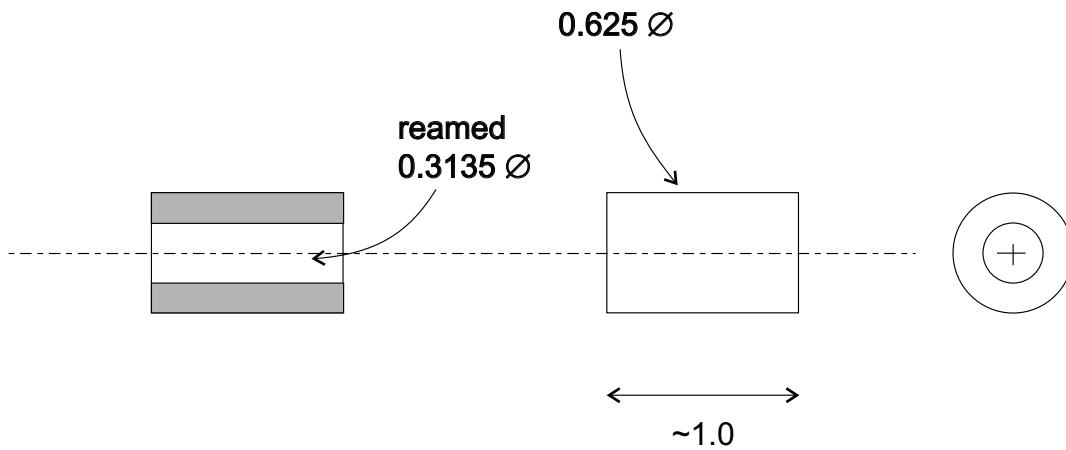

tail bearing

material: Delrin

make oversize and trim
to fit body

Dewit Hurdy-gurdy

Supplemental Plans - Bearings

FS (1" = 1")

Copyright 1996, Olympic Musical Instruments
v2.0 Feb 22, 1996

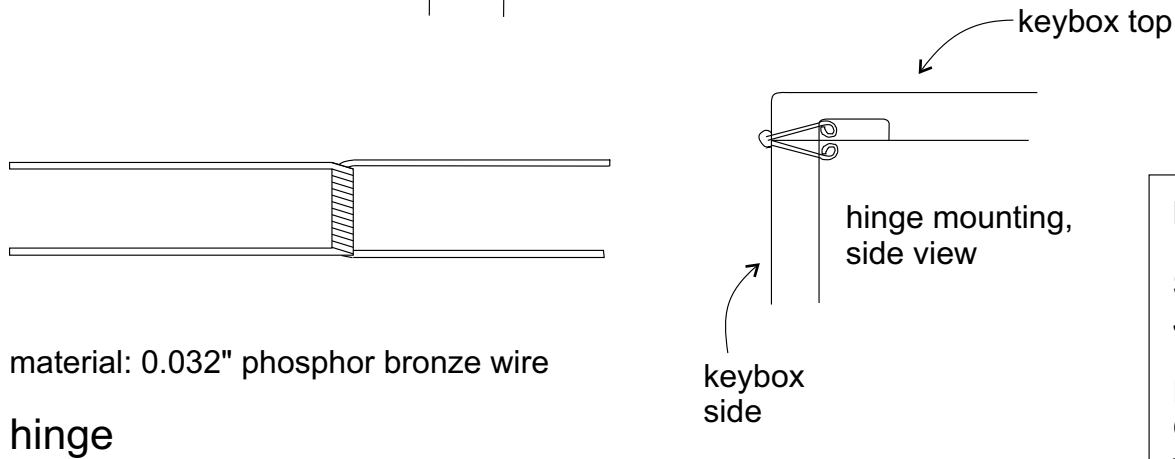
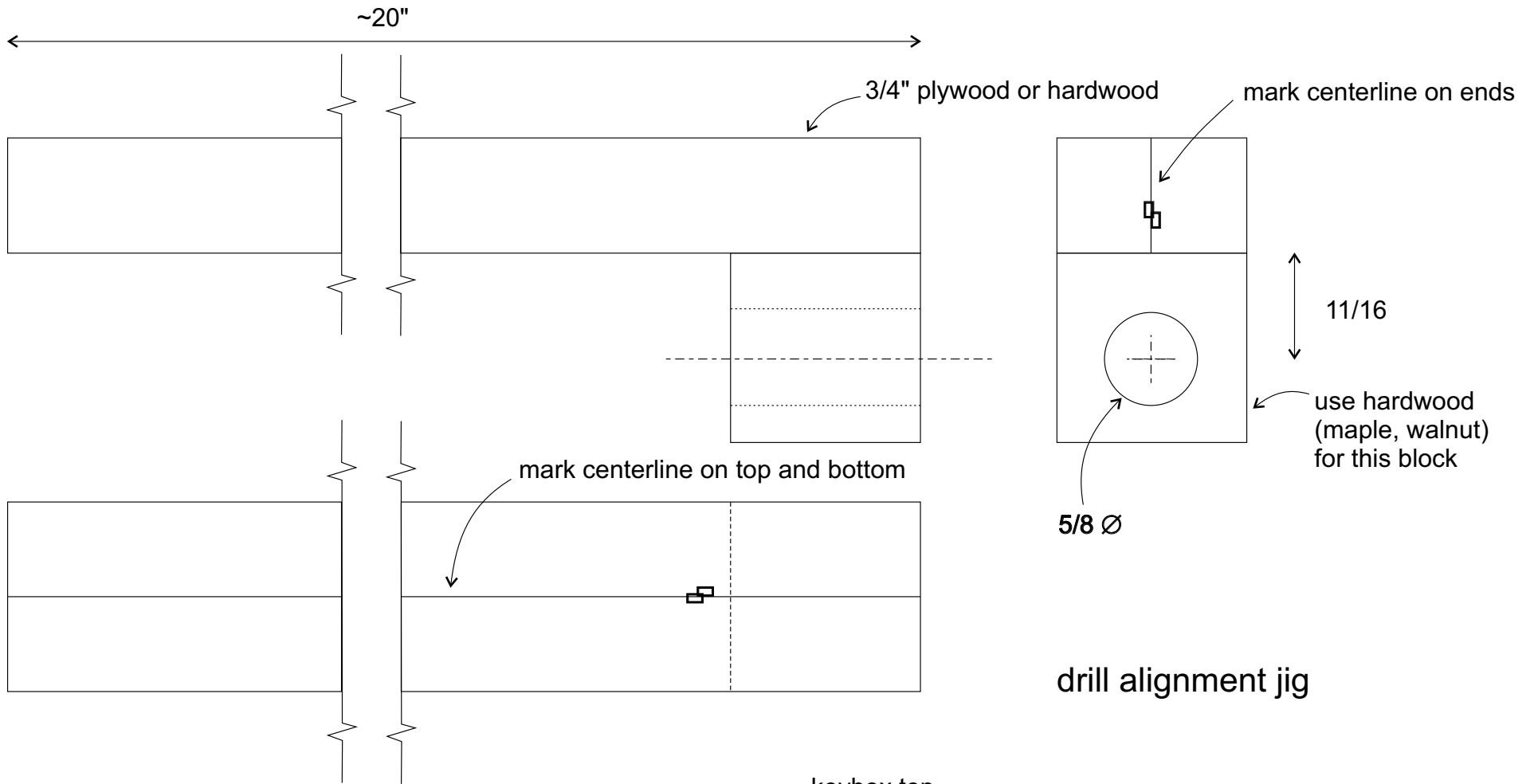

Dewit Hurdy-gurdy

Supplemental Plans - Hinge, Drill Alignment Jig

FS (1" = 1")

Copyright 1996, Olympic Musical Instruments
v2.0 Feb 22, 1996

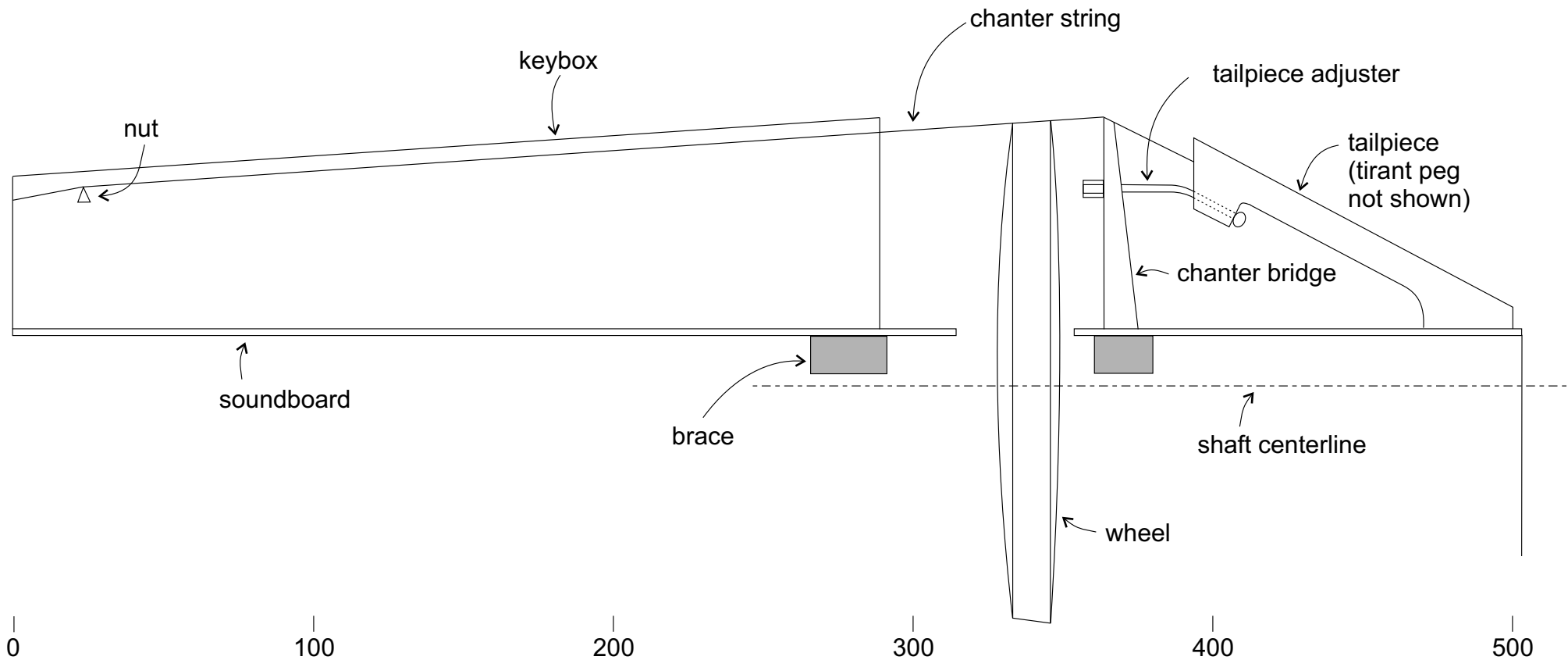

Dewit Hurdy-gurdy

Supplemental Plans - elevation

Scale: 1" = 50mm

Copyright 1996, Olympic Musical Instruments

v2.0 Feb 22, 1996

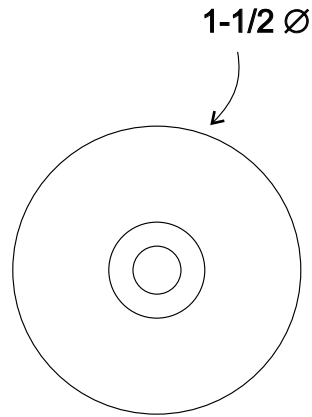
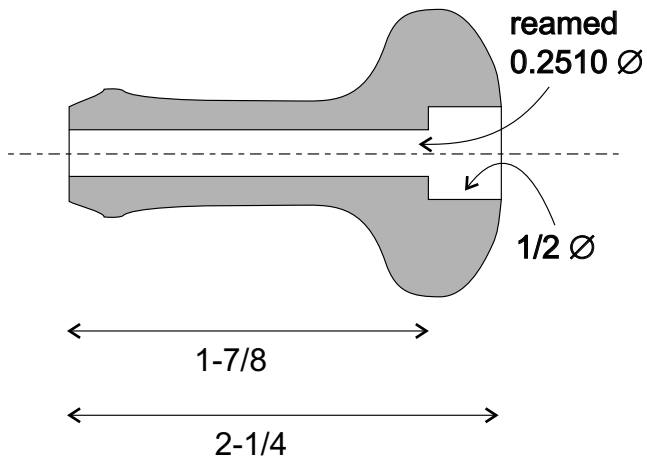

handle
material: hardwood

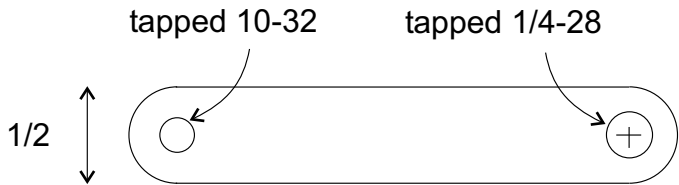

crank
material: brass (360)

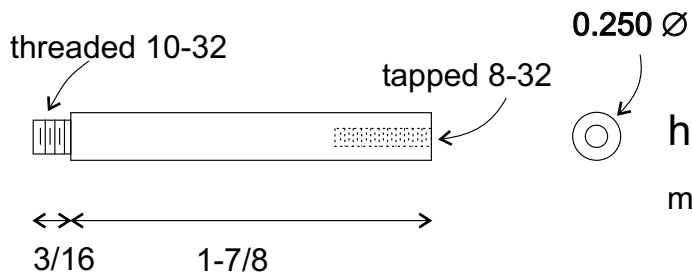
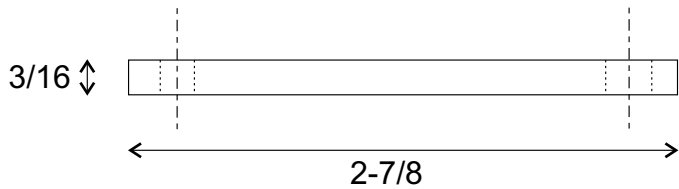

handle shaft
material: 1/4" drill rod

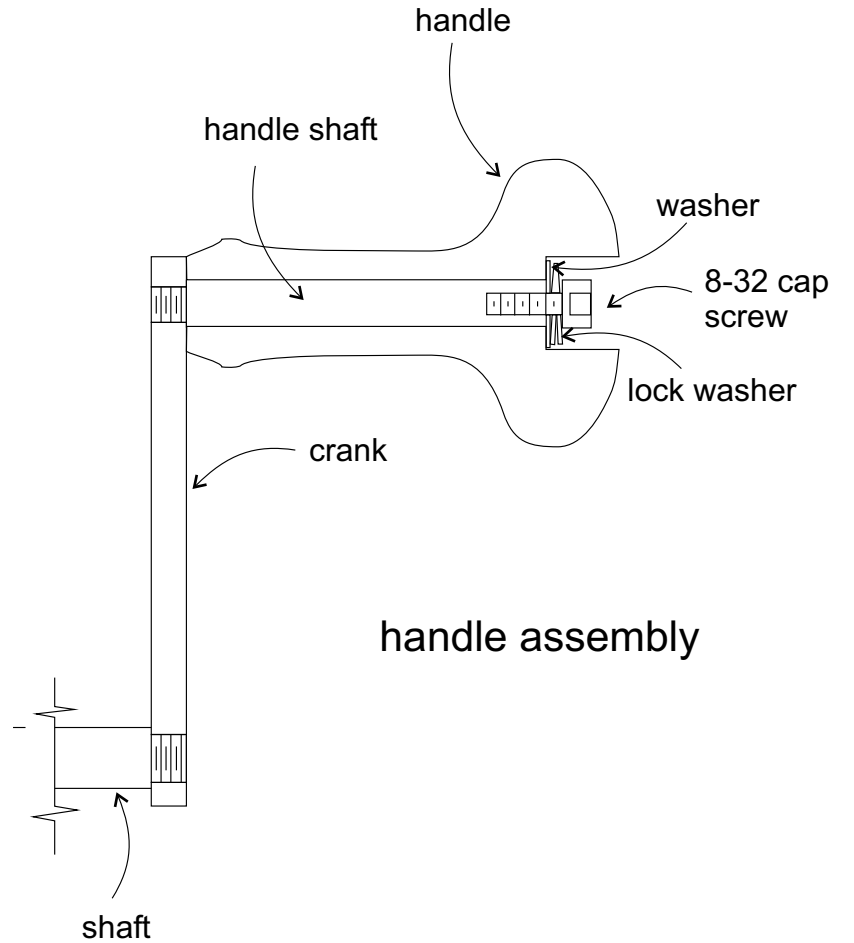

Dewit Hurdy-gurdy

Supplemental Plans - Handle

FS (1" = 1")

Copyright 1996, Olympic Musical Instruments
v2.0 Feb 22, 1996

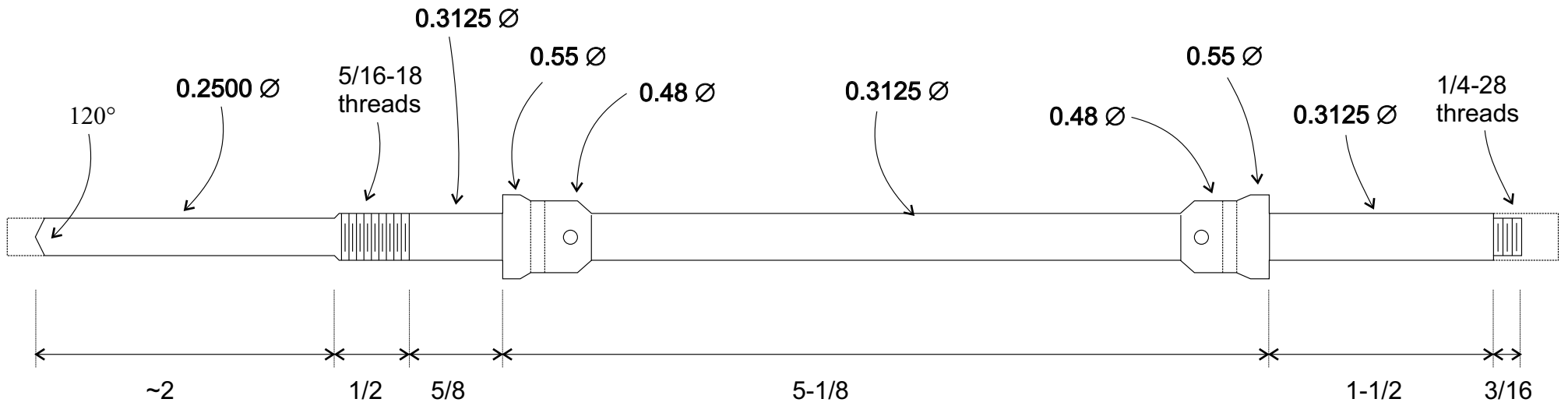

leave ends ~1/4" oversize and trim to length when fitting

materials: shaft body: 5/16" drill rod
 thrust collars: 5/8" CRS
 thrust collar pins: 3/32" drill rod or brass rod

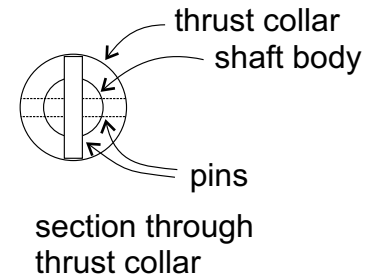

shaft

Dewit Hurdy-gurdy

Supplemental Plans - shaft

FS (1" = 1")

Copyright 1996, Olympic Musical Instruments
 v2.0 Feb 22, 1996

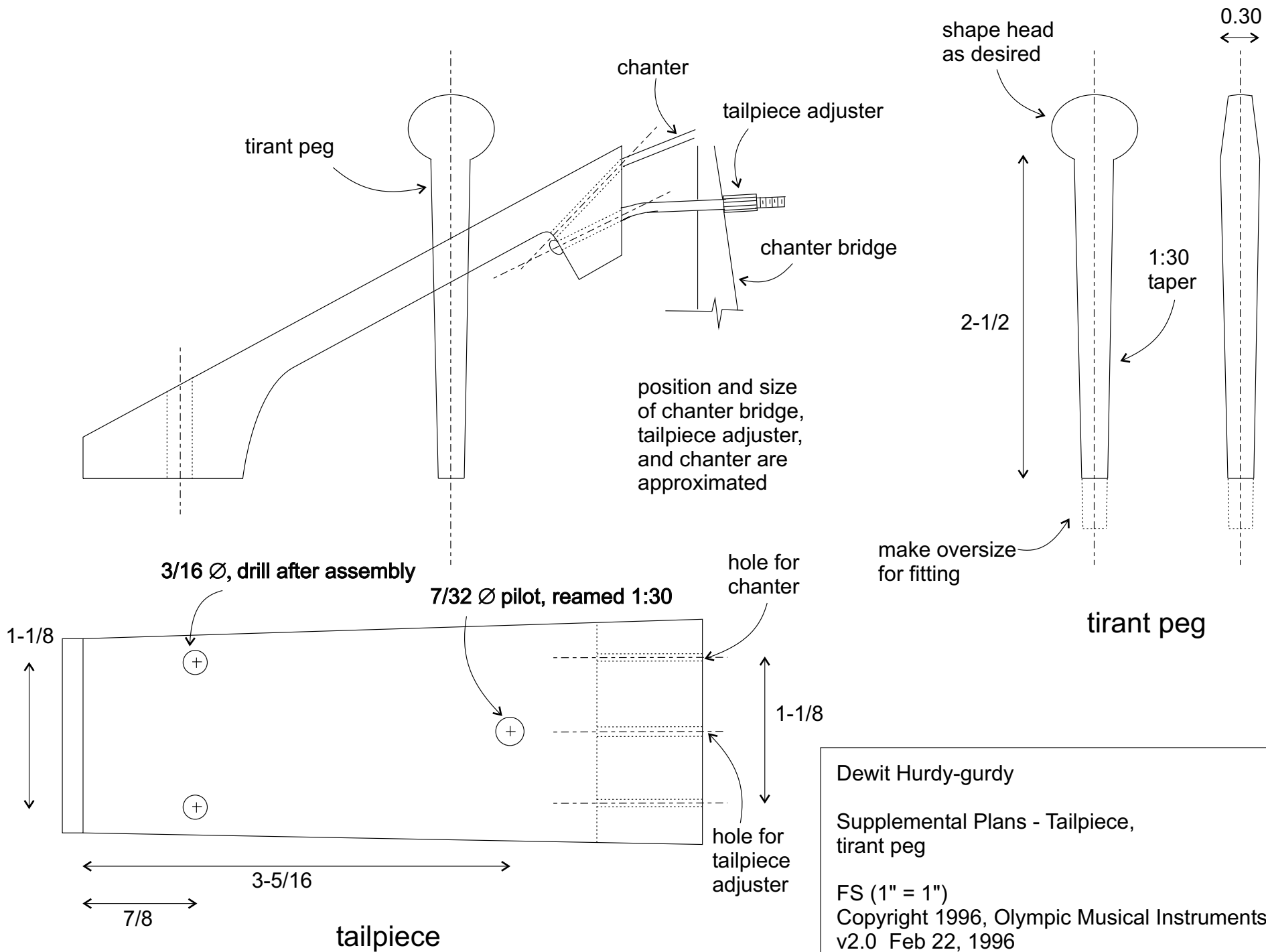

Dewit Hurdy-gurdy
 Supplemental Plans - Tailpiece,
 tirant peg
 FS (1" = 1")
 Copyright 1996, Olympic Musical Instruments
 v2.0 Feb 22, 1996

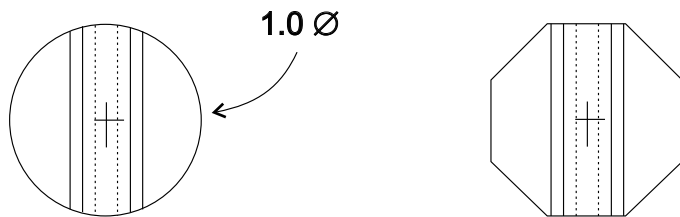
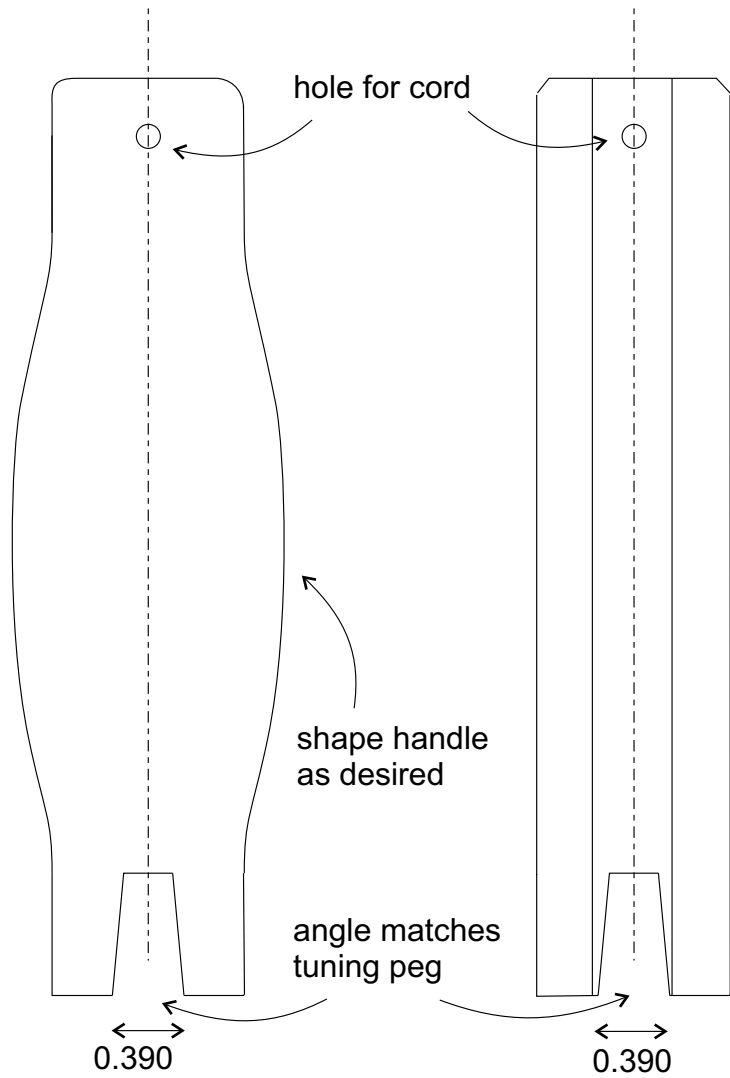

Tourne-a-gauche (2 designs)

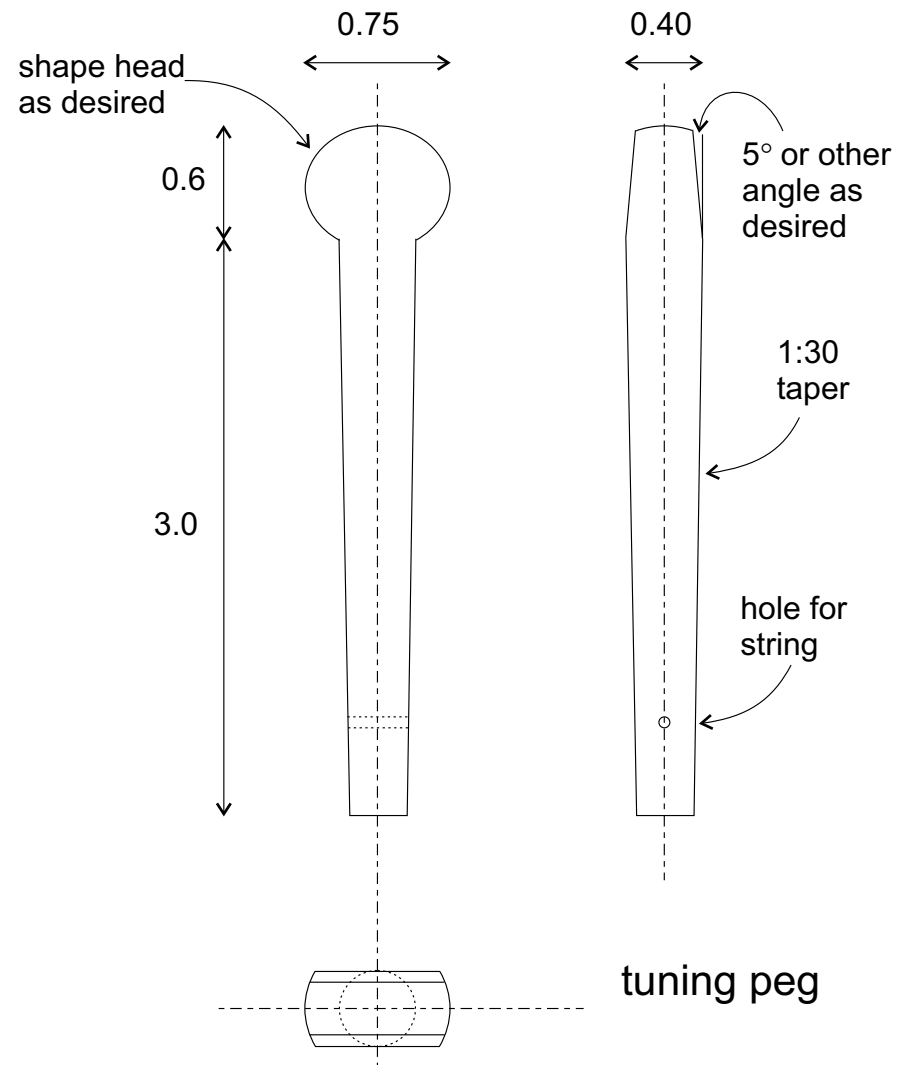

Dewit Hurdy-gurdy

Supplemental Plans - Tuning peg,
Tourne-a-gauche

FS (1" = 1")

Copyright 1996, Olympic Musical Instruments
v2.0 Feb 22, 1996

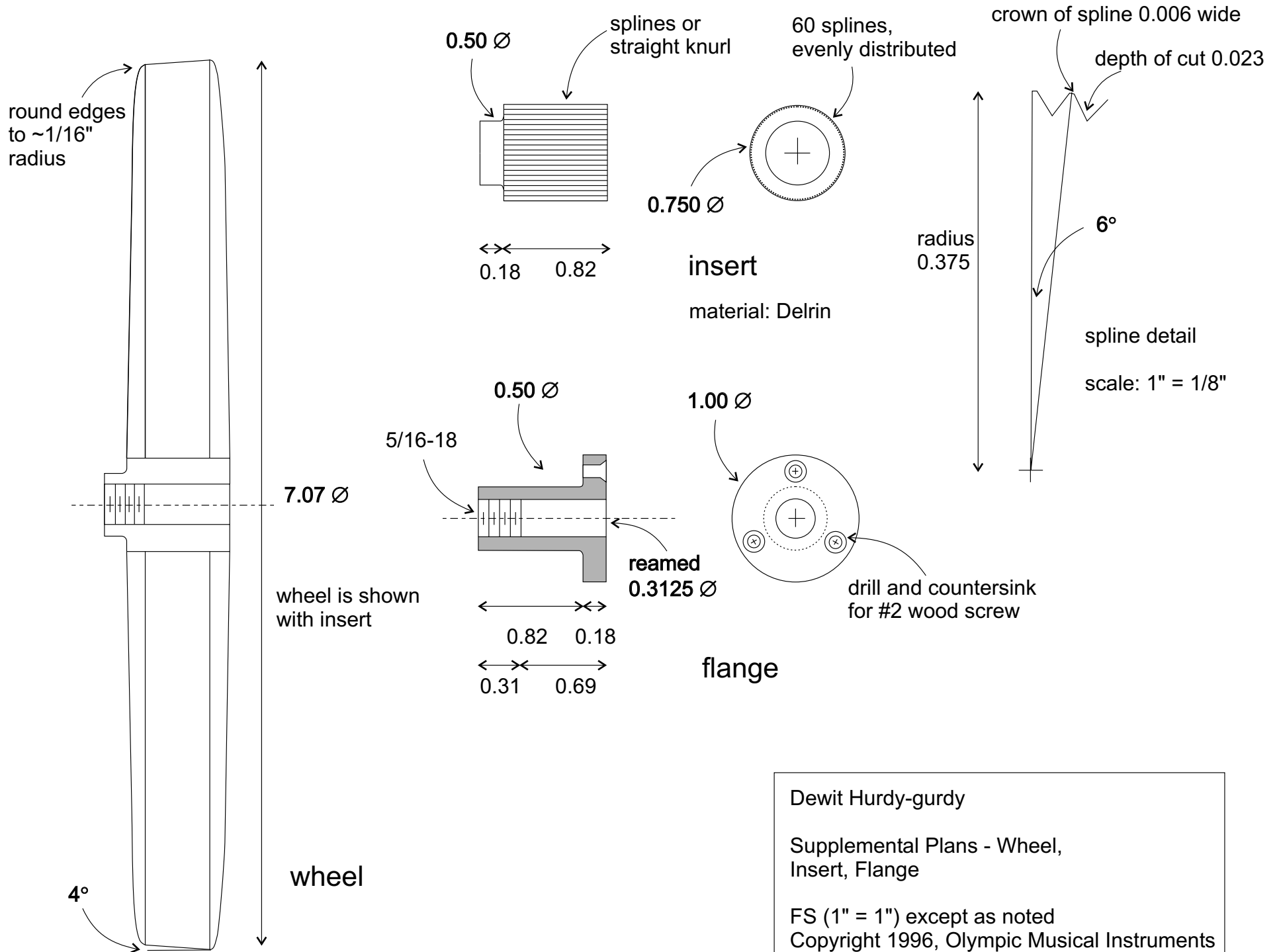

Dewit Hurdy-gurdy

Supplemental Plans - Wheel,
Insert, Flange

FS (1" = 1") except as noted
Copyright 1996, Olympic Musical Instruments
v2.0 Feb 22, 1996